

# **Speedwoofer 10S<sub>MKII</sub>**

## OWNER'S MANUAL

Written by people who hate owners manuals and have limited attention spans.



 **SPEAKERS**

# IMPORTANT SAFETY INSTRUCTIONS

**READ THIS SECTION CAREFULLY BEFORE PROCEEDING!**

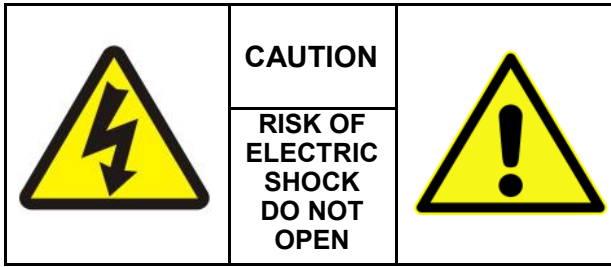

**CAUTION:** To reduce the risk of electric shock, do not remove the cover (or back). No user serviceable parts inside. Please refer all servicing to licensed service technicians.

**WARNING:** To reduce the risk of fire or electric shock, do not expose this appliance to rain or moisture. Objects filled with liquids, such as vases, should not be placed on this appliance.

**CAUTION:** To prevent electric shock, match the wide blade of the AC power plug to the wide slot of the wall plug and insert it fully.

**WARNING:** This device generates a fair amount of heat. Do not place near a heat source or in spaces that can restrict ventilation.

**CAUTION:** For continued protection against risk of fire, replace the fuse only with the same amperage and voltage type. Refer replacement to qualified service personnel.

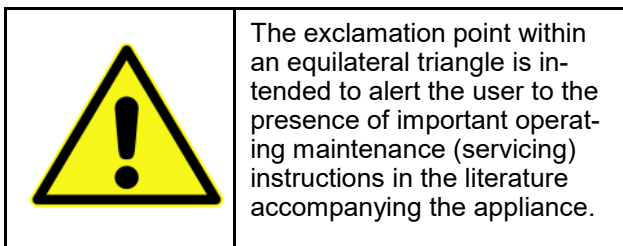
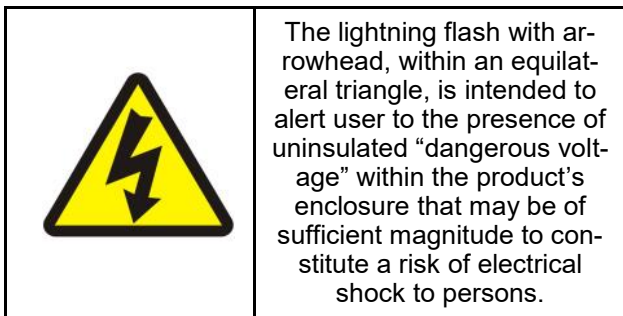

1. **Read These Instructions** – before operating.
2. **Retain These Instructions**
3. **Heed All Warnings And Follow All Instructions.**
4. **Cleaning** – Unplug this product from the wall outlet before cleaning. Do not use liquid cleaners or aerosol cleaners. Use a damp, soft cloth for cleaning.
5. **Water and Moisture** – Do not use this product near water. For example, near a bath tub, wash bowl, kitchen sink, or laundry tub; in a wet basement; or near a swimming pool; and the like.
6. **Accessories** – Only use attachments or accessories specified by the manufacturer. Do not place this product on an unstable cart, stand, tripod, bracket or table. The product may fall, causing serious injury to a child or adult and serious damage to the product. When a cart is used, use caution when moving the cart/apparatus combination to avoid injury from tip-over.



7. **Ventilation** – Slots and openings into the cabinet are provided for ventilation and to ensure reliable operation of the product and to protect it from overheating, and these openings must not be blocked or covered. The openings should never be blocked by placing the product on a bed, sofa, rug, or other similar surface. This product should not be placed in a built-in installation such as a bookcase or rack unless proper ventilation is provided or the manufacturer's instructions have been adhered to.

## IMPORTANT SAFETY INSTRUCTIONS — Continued

8. **Power Sources** – This product should be operated only from the type of power source indicated on the marking label. If you are not sure of the type of power supply to your home, consult your product dealer or local power company.
9. **Grounding and Polarization** – This product may be equipped with a polarized alternating-current line plug (a plug having one blade wider than the other). This plug will fit into the power outlet only one way. This is a safety feature. If you are unable to insert the plug fully into the outlet, try reversing the plug. If the plug should still fail to fit, contact your electrician to replace your obsolete outlet. Do not defeat the safety purpose of the polarized plug.
10. **Power-Cord Protection** – Power supply cords should be routed so that they are not likely to be walked on or pinched by items placed upon or against them, paying particular attention to cords at plugs, convenience receptacles, and the point where they exit from the product.
11. **Lightning** – For added protection for this product during a lightning storm, or when it is left unattended and unused for long periods of time, unplug it from the wall outlet.
12. **Servicing** – Do not attempt to service this product yourself as opening or removing covers may expose you to dangerous voltage or other hazards. Refer all servicing to qualified service personnel.
13. **Damage Requiring Service** – Unplug this product from wall outlet and refer servicing to qualified personnel under the following conditions:
- When power cord or plug is damaged;
  - If liquid has been spilled, or product is exposed to rain or water or it objects have fallen onto product;
  - If the product does not operate normally.
  - If the product has been dropped or damaged in any way;
14. **Replacement Parts** – Use only replacement parts specified by the manufacturer.. Unauthorized substitutions may result in fire, electric shock, or other hazards.
15. **Heat** – The product should be used away from heat sources such as radiators, heat registers, stoves, or other heat-producing products.
23. **WARNING:** The 115V~/230V~ voltage selector must be set to the correct local voltage with the proper Fuse installed.
24. **Plastic Bags** – Be sure to keep all plastic bags away from infants and small children to prevent the risk of choking or suffocation.



**WARNING: SHOCK HAZARD - DO NOT OPEN**

**AVIS: RISQUE DE CHOC ELECTRIQUE - NE PAS OUVRIR**

**CAUTION:**

DISCONNECT POWER CORD BEFORE CHANGING FUSE. REPLACE WITH SAME TYPE OF FUSE.

**ATTENTION:**

DEBRANCHER AVANT DE REMPLACER LE FUSIBLE. UTILIZER UN FUSIBLE DE

We can't figure out why they make us write these in French as opposed to Klingon or some other language.



# Table Of Contents

IMPORTANT SAFETY INSTRUCTIONS.....	2
INTRODUCTION.....	5
COMPRESSION GUIDE TECHNOLOGY - A LITTLE HISTORY.....	5
SPEEDWOOFER 10SMKII FEATURES.....	7
FIRST STEPS.....	7
ROOM ACOUSTICS.....	8
POSITIONING YOUR SUBWOOFER.....	8
MULTIPLE SUBWOOFERS.....	9
HOME THEATER INSTALLATION.....	9
STEREO INSTALLATION.....	10
PROTECTING YOUR SPEAKERS.....	11
CONNECTING YOUR SUBWOOFER WIRELESSLY.....	12
WIRELESS CONNECTION INFORMATION.....	13
CONNECTING DUAL SUBWOOFERS.....	13
SOME INSTALLATION TIPS.....	14
A DISCUSSION ABOUT MAXIMUM BASS OUTPUT.....	15
CARE AND MAINTENANCE.....	15
OPERATING YOUR SUBWOOFER.....	16
TROUBLESHOOTING.....	18
SPECIFICATIONS.....	18
WARRANTY.....	19
IMAGINERY PAGE.....	20

Note: Any mistakes in this manual were intentionally placed to test your alertness.

# Your New Speedwoofer 10SMKII

The original RSL Speedwoofer 10S was introduced in 2016. Since that time, it has racked up numerous awards, including several product of the year titles. It set a standard for what's possible from a compact, affordable 10 inch subwoofer. Its patented Compression Guide tuning allowed it to outperform sealed subwoofer designs when it came to accuracy and it also matched the bass impact usually associated with larger 12 inch ported subwoofers.

Your new RSL Speedwoofer 10SMKII elevates performance even further. Its all-new amplifier design has increased power output at 400W RMS. Built-in DSP (digital signal processing) allows better usage of the available power to further increase frequency response and output. The Speedwoofer 10SMKII digs deeper in the bass with usable response that extends down to 20 Hz. With DSP, you can now choose between 2 sound modes. One mode duplicates the sound characteristics of the original Speedwoofer 10S. The other mode extends the bass even further to increase the impact from movies.

The Speedwoofer's rugged, cast-frame woofer has been improved to handle the increased power of the amplifier. In addition, the Speedwoofer's exclusive Compression Guide tuning has been revised. This along with a new rear vent further reduces any potential port noise or chuff.

When it comes to bass, quality is as important as quantity. It's easy to produce an inexpensive subwoofer that produces gobs of low end. However, getting it to do it cleanly is a lot more difficult. Many affordable subwoofers sound sloppy and localize, which means they draw attention to themselves. The bass they produce seems separate from the rest of the sound. You can sense that bass is coming from the location of the subwoofer. With a properly designed subwoofer, bass should sound as if it is coming from its actual location in the sound track. With the new Speedwoofer 10SMKII, precision and accuracy is maintained.

## Before You Dig In!

We know the temptation is great to tear into the carton, unpack your new sub and fire it up. If that urge seems overwhelming, then go right ahead. It's unlikely that you'll hurt anything. However, subwoofers do need a bit of fine tuning in order to experience their full capabilities. The goal of this thrilling, action-packed owner's manual is to help you enjoy the full performance of your new Speedwoofer.

Many of you (and us as well) don't like having to suffer through owners manuals. Most manuals try to answer all questions, except the one you may have. We've tried to make this manual as easy to read as possible and even helpful at times. However, if you already have enough knowledge about subwoofers and you know not to do the dumb things warned about in the safety pages, be our guest and start enjoying your Speedwoofer 10SMKII.

Since we don't know about your particular audio setup, whether it's home theater or stereo, we've tried to cover all the bases. So feel free to skip around and only read what's of interest.

## Compression Guide Technology - A Little History

Part of the Speedwoofer 10SMKII's accurate bass response is due to our exclusive Compression Guide Technology. A number of years ago, we noticed that almost all speakers (including early RSLs) suffered from a problem. It was an awareness that the sound of bass over speakers was quite different from bass at a live performance. When you'd hear bass live, you would hear various details in the bass as well as feel the impact.

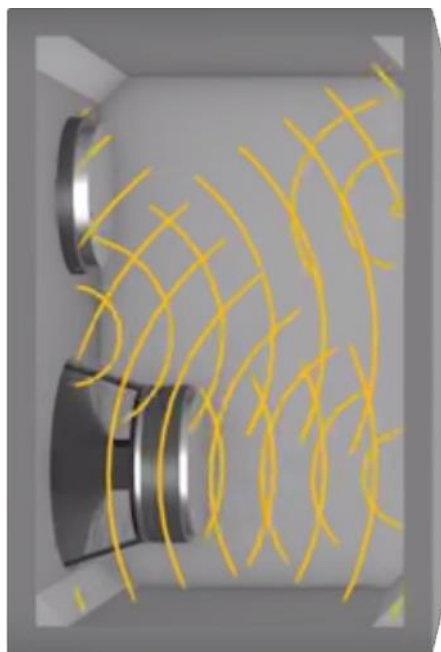

**Standard Enclosure**

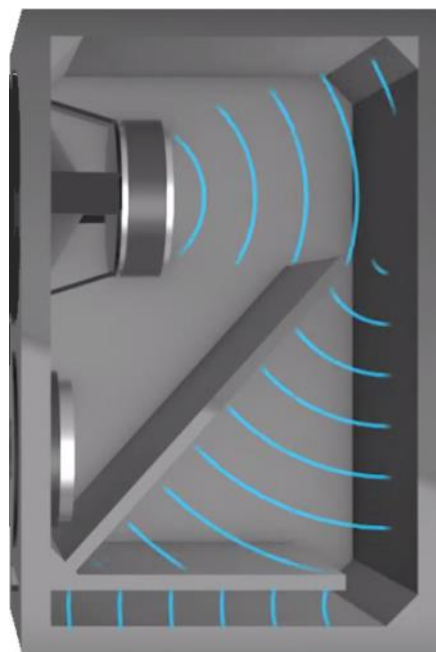

**Compression Guide Enclosure**

## **Compression Guide Technology - History - Continued**

For example, with a bass guitar, you can hear the pick of the string along with the bass note. With a kick drum, you could hear the rap of the mallet against the skin of the drum and your body could feel the impact. However, with conventional speakers, all you'd hear was an ill-defined boom. Back then, the only speakers that seemed to get it right were the big, bulky and expensive transmission-line systems.

We needed to know why there was a disparity between live bass and that reproduced by speakers. After some research, it became apparent that the problem was due to the way the woofer was tuned in the enclosure. As was the case then just as it is now, two tuning methods were used by most speaker companies. In one case the cabinet was completely sealed. This method is called acoustic suspension or air suspension. In the other method, the cabinet had a calculated opening called a vent or port. The length, width and height of the port was designed to reinforce bass at the lowest frequencies.

The problem with both of these methods is that they rely on system resonance to properly load the woofer. System resonance acts like a spring in that once a note stops, the woofer cone wants to continue vibrating. This results in what we call woofer overhang and results in muddy bass. After realizing the problem, we spent years attempting to lessen the effects of system resonance. Eventually, we found the solution and the results were spectacular. We call it Compression Guide and it was a method of dividing the insides of the speaker enclosure into areas of compression and expansion. As the sound wave passed through these areas, the effects of resonance were greatly reduced.

We discovered that Compression Guide also paid huge dividends in the midrange as well. Bookshelf speakers tuned by Compression Guide exhibited much cleaner and transparent sound with both vocals and music. In comparison, other bookshelf speakers sounded "boxy". It also helped the speakers to image more accurately.

# Speedwoofer 10 SMKII Features

- Improved Compression Guide Technology Tuning with rear venting.
- Precision 10" woofer with heavy, die-cast aluminum frame, massive magnet structure and motor assembly. This allows the cone, along with its surround to achieve high excursions, delivering deep, powerful bass with complete control and linearity.
- Powerful 400 Watt RMS Digital Amplifier. This efficient amplifier minimizes power consumption (around 1 watt in standby mode, only slightly higher in operation mode with no signal). Because amplifier standards are not strictly enforced, many manufacturers would rate this amplifier at a much higher wattage. If this amplifier were rated in peak power (a specification we don't agree with) it could be rated in excess of 1,000 watts.
- New integrated DSP maximizes output at all frequencies extends the frequency response for deeper bass. Two sound modes are available.
- Dense MDF wooden cabinet with internal bracing. Unlike most subwoofers, the Speedwoofer 10S's enclosure is completely filled with damping material to further reduce unwanted resonances.
- Wireless capability. The Speedwoofer 10S has a wireless receiver built in. If you are unable to run an audio cable to the subwoofer, you can purchase our optional wireless transmitter and get full performance wirelessly.

## First Steps

- Be careful when using sharp objects to open boxes. The insertion of a long and/or sharp object such as a blade can damage the components inside. Use of chainsaws, machetes, power tools, explosives, light sabers, and most kitchenware is not recommended. If in doubt, ask mommy to help you.
- Please take a moment to inspect your subwoofer for damage. If you find any damage that you did not specifically request, please contact us or the shipping company immediately and take photos of the box and subwoofer. All components have been inspected when leaving our factory; however damage can occur during shipping.
- If possible, we recommend saving all packaging, including boxes, as a convenient means of re-packaging for moving or for sending your subwoofer in for service (in the unlikely event it needs it).
- You will need either an RCA cable or the optional wireless transmitter to connect the subwoofer. If you purchase an RCA cable, you do not need to buy an expensive one. Subwoofers reproduce a narrow band of frequencies, typically 20-200 Hz. Do not allow some slick, fast-talking, know-it-all salesperson to convince you to spend a lot on this cable. Just purchase a cable that is well-constructed and has good shielding to reduce interference.

# More Than You Probably Want to Know About Room Acoustics

The acoustical characteristics of your listening room has a major effect on sound quality. This is so important, it bears repeating (so feel free to re-read the first sentence). If your room has good acoustical qualities, even mediocre speakers can sound pretty good. In turn, if your room has poor acoustics, high-end speakers can sound lacking. Acoustical qualities are determined by the dimensions of your room and the amount of sound-absorbing materials present.

Because this manual covers the installation of your new subwoofer, we will concern ourselves with how your room's acoustics affect bass. Bass distribution is strictly determined by a room's dimensions. A room with evenly distributed bass will deliver the same volume of bass in different seating positions. Obviously, you can't do a heck of a lot about the dimensions of your room. Don't worry; few rooms are close to perfect. You can however maximize the evenness of bass distribution by properly positioning your subwoofer (if you have that flexibility) and or using multiple subwoofers.

While virtually all of today's Audio/Video receivers and processors include microphones and room correction circuitry that can help to smooth bass frequency response, they will not correct for bass distribution problems.

## Positioning Your Subwoofer

The position of the Speedwoofer in your room has a tremendous effect on the results it provides. There is a wealth of information online in forums and review sites regarding subwoofer placement. If you have the flexibility to place your Speedwoofer in different positions, we suggest doing some experimentation to determine the best spot. The goal is to get an even volume of bass in your various listening positions. Here is some basic and by no means complete information about subwoofer positioning.

- Bass distribution in a particular room is determined by the dimensions of the room. Every room has locations of peaks (where bass is increased) and nulls (where bass is substantially decreased). If your seating position is in a peak, the amount of bass can be reduced through equalization. However, if your seating position is in a null, bass cannot be significantly increased (attempting to do so wastes power).
- Placing a subwoofer near a wall will increase the volume of bass. Always allow a few inches between the wall and your subwoofer. This is necessary for airflow to the amplifier and for airflow emanating from the rear port or vent.
- Placing a subwoofer in a corner will further increase its output.

Here is an example of one method commonly used to determine subwoofer position. Connect your subwoofer and temporarily place it in your listening position (on the sofa, etc.). Then, while playing some music with a constant bass track, crawl around the perimeter of your room and find the spot where the bass seems to have the best quality and quantity (don't let anybody see you, otherwise you'll have some explaining to do). Then, place the subwoofer in the spot where you heard the best bass. You can repeat this for different listening positions and see if you can find the best subwoofer position that accommodates the most listening positions.



## Multiple Subwoofers

The majority of our customers are quite happy with the performance of a single Speedwoofer. However, many audio experts recommend dual subwoofers. They feel that with two or more subs it's much easier to get consistent bass distribution by placing the two subs in different positions. Multiple subs also deliver more powerful bass throughout the room.

If you want foundation-cracking levels of bass, dual subwoofers can achieve a up to a 6db gain in bass output. While that may not seem like a lot, for an amplifier to deliver 3db more volume, its power must double! If you place dual subwoofers near each other, you'll get approximately a 6db gain in bass volume. That's huge!

Some of the many ways of positioning multiple subwoofers include:

- Subwoofers next to or on top of each other.
- Subwoofers in each corner.
- Combination of subwoofers in corners and midpoints along the wall.

As in the above section on positioning, there is a lot of information online and we highly encourage experimentation to find the best positions for your Speedwoofers.

## Home Theater Installation

We have designed the Speedwoofer 10S to accommodate both home theater as well as stereo systems. The most common installation will be with an A/V receiver or processor. In this case, all you'll need is a single RCA cable and a wall outlet. The RCA cable does not have to be expensive as the subwoofer only reproduces a narrow band of frequencies. However choose a cable that is well-shielded and constructed to last.

Connect one end of the RCA cable to your receiver or processor's subwoofer (or LFE) output. Connect the other end to the Speedwoofer's LFE input. Then, **set the Speedwoofer's internal crossover to bypass by rotating the crossover frequency knob fully counter-clockwise until it clicks and points to the LFE mode.** You will not be using the Speedwoofer's internal crossover, because that function is performed by your A/V receiver or processor. It will also set the DSP to the LFE mode (more about this in the section about DSP settings).

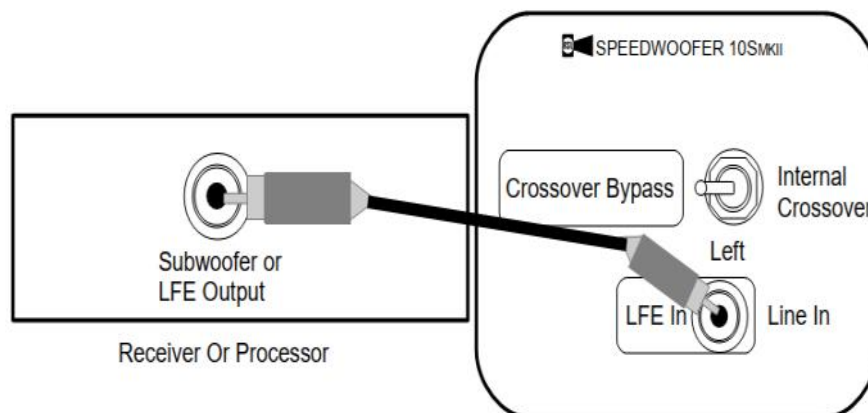

**Connection to A/V Receiver Or Processor**

# The Easiest Stereo Installation Section You Will Find!

(In this manual) (If you are a home theater user, please skip to page 12)

The RSL Speedwoofer 10SMKII can be used in virtually all stereo systems. Depending on your equipment, there are different options for hooking up your Speedwoofer.

## If Your Stereo Receiver Or Amplifier Has Pre-amplifier Outputs

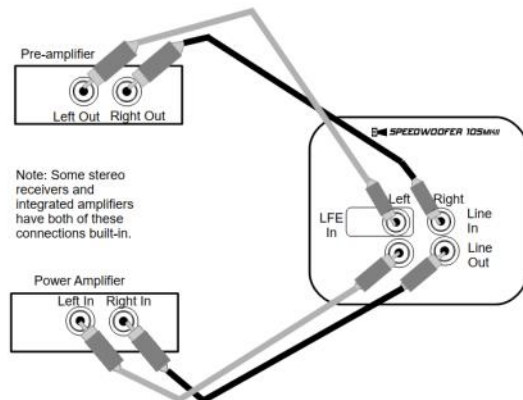

### Method #1 - Connection Through The Speedwoofer 10S

This method, requires 2 pairs of RCA cables. One pair of cables is connected from your preamplifier (or receiver's pre-amplifier) outputs to the Speedwoofer's left and right line inputs. Then another pair is connected from the sub's left and right line outputs to your power amplifier (or back into your receiver's power amplifier inputs). The audio signal travels from your pre-amplifier through the subwoofer giving the subwoofer the audio it needs and then back out to your power amplifier and to your speakers. In this method, the Speedwoofer's internal crossover is used to control the bass of the subwoofer. To use, set the crossover frequency control to the desired crossover frequency. This also selects the DSP's music mode (more about this in the section about DSP settings).

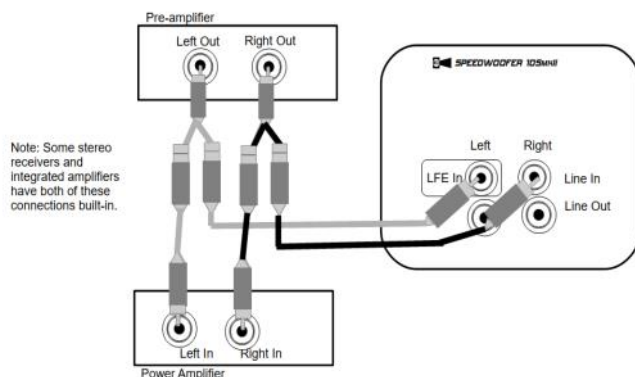

### Method #2 - Connection Using Y Adapters

In this method, you also will need two pairs of RCA cables, however the lengths on one may be shorter. You will also need two Y Adapters that split the audio into two RCA connections. Connect a Y adapter to left pre-amplifier output and the other Y adapter to the right pre-amplifier output. Then connect one pair of cables from the left and right pre-amplifier outputs to the Speedwoofer's left and right line inputs. The other pair of cables connect from the left and right pre-amplifier's outputs to the power amplifier's left and right inputs. Please see the diagram above. As in the first method, the Speedwoofer's internal crossover is used to control the bass reproduction of the subwoofer. Set the crossover frequency control to the desired crossover frequency. This also selects the DSP's music mode (more about this in the section about DSP settings).

# Receivers And Amplifiers With No Pre-amplifier Outputs

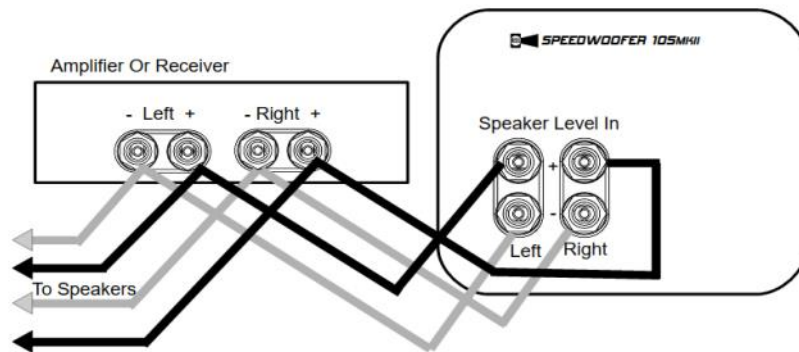

## Method #3 - Connection Using Speaker Wires

If your equipment can't accommodate the first two methods, use this method. You will need an additional pair of two-conductor speaker wires. In addition to your main speaker connections, you'll run a second set of wires to your subwoofer (see diagram above). As in the above methods, you'll use the Speedwoofer's internal crossover. Set the crossover frequency control to the desired crossover frequency. This also selects the DSP's music mode (more about this in the section about DSP settings). In the unlikely event you encounter hum or noise, please see the solution explained in the troubleshooting section of this manual.

## Caution: Protect Your Speakers

In a normal home theater system, the A/V receiver or processor protects the other speakers in the system by filtering off the bass when you set the crossover frequencies. This is especially important when your other speakers are smaller and not designed to handle low-bass frequencies. In the above three methods of connecting your subwoofer in a stereo system, your amplifier will deliver all of the bass to your other speakers. If the speakers are small, damage could result if played at a very loud volume. However, you can protect your smaller speakers by using external inline filters to reduce the bass frequencies going to your speakers. These filters plug inline with your RCA cables. If you would like us to recommend the correct filters for your system, please contact us. Please note that you can only use this solution with methods #1 and #2. If you need to use method #3 and are concerned about protecting your smaller speakers, please also contact us.

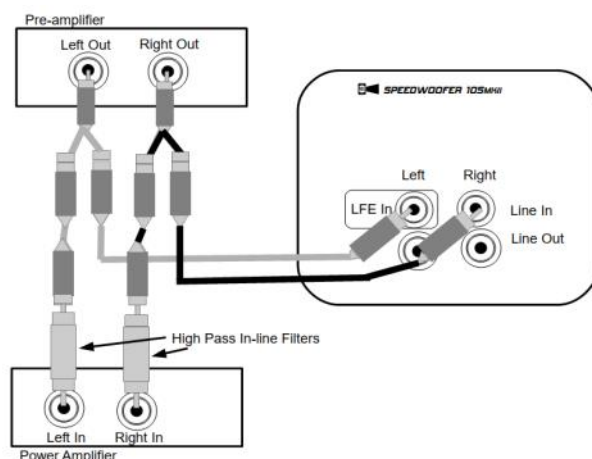

## Protecting Your Speakers With In-Line Filters

# Connecting Your Subwoofer Wirelessly

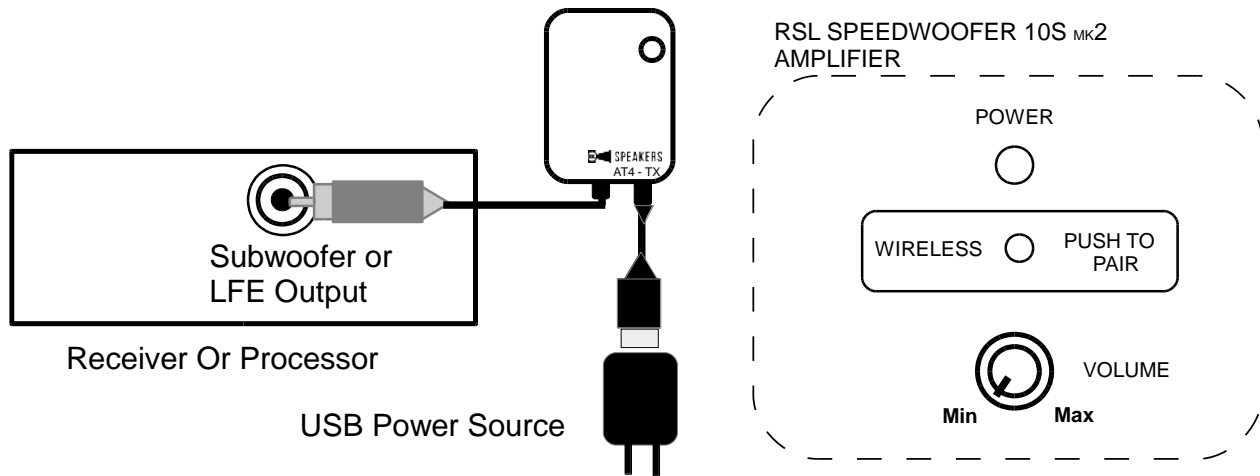

The optional RSL AT4 wireless transmitter lets you send audio wirelessly to a receiver built-in to the Speedwoofer 10SMKII. A wireless connection can be handy when it's difficult to run an RCA cable to your subwoofer.

Another benefit is that it makes it easy to experiment placing your Speedwoofer in different listening positions.

The RSL AT4 Wireless Audio Transmitter has a range up to 50 ft. The first time you setup the AT4 for wireless use, you will need to pair it with the Speedwoofer. You should only need to do this once.

## Wireless Transmitter Pairing Instructions

1. Plug the Speedwoofer in to a wall outlet and turn on the power.
2. Connect the AT4 to an output from your A/V receiver, processor, integrated amplifier, or pre-amplifier. Use either the included mono or stereo RCA cable.
3. Connect the transmitter to a USB power source. **Please use the included USB wall adapter or an independent power source. If you use your Audio/Video receiver or other A/V component as a USB power source you may experience interference.**
4. The light on the transmitter will flash slowly. Push and hold the transmitter's pairing button until it flashes rapidly and then release the button.
5. Immediately while it is flashing rapidly, press and hold the pairing button on the Speedwoofer for 3-4 seconds and release it. Do not hold the pairing button any longer than 4seconds. The transmitter light should display solid blue.
6. Your Speedwoofer is now paired.
7. If the transmitter light begins to flash slowly, repeat the above procedure. If pairing still fails, temporarily place the AT4 transmitter closer to the Speedwoofer and away from other Wi-Fi devices. The transmitter does not need an audio connection in order to pair it.

**Please Note: Solid objects such as walls, cabinet doors, etc. can block the wireless signal. Its signal can also be affected by interference from wireless networks, large objects and other electronic devices.**

## Wireless Connection Information (Important)

If you are using your RSL Speedwoofer 10SMKII wirelessly, here is some additional information you should know:

- When pairing the wireless transmitter to the Speedwoofer, the Speedwoofer's pairing button must be held for 3 or 4 seconds and no longer.
- Holding the Speedwoofer's pairing 6 seconds or longer will temporarily unpair the Speedwoofer. This can be useful if you wish to change to a wired connection. When the Speedwoofer is temporarily unpaired, you will be able to use an RCA cable instead of sending the signal wirelessly. However, it is important to note that if the Speedwoofer is unplugged from an AC outlet or its power switch is turned off, the Speedwoofer will resort to its wireless connection. To avoid this, leave the wireless transmitter's power cable disconnected or use an in line power switch to turn off the transmitter when not in use.
- Using the Speedwoofer wirelessly will result in it always staying in operation mode. This is OK, because in operation mode with no signal applied, power consumption is only slightly higher than in standby mode. This has no effect on the longevity of the Speedwoofer's amplifier. However, if you wish to have the Speedwoofer go into standby mode, you can unplug the power to the transmitter when not in use or install an inexpensive inline power switch to turn it off.
- If you wish your Speedwoofer to be permanently unpaired to your transmitter, it can be paired to a different transmitter. Then, it will forget the first transmitter. Or, you can just not power on your transmitter and the Speedwoofer will always use a wired connection.

## Connecting Multiple Subwoofers

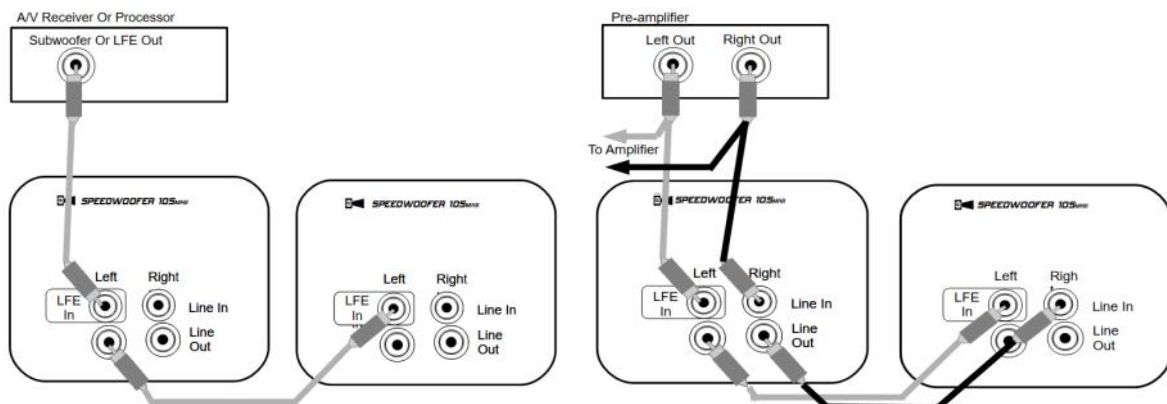

**Connecting Two Subs - A/V Receiver Or Processor**

**Connecting Two Subs - Stereo**

There are three ways to connect dual subwoofers. Many of today's A/V receivers and processors provide two subwoofer or LFE connections. With these, you can run separate RCA cables to each of your subwoofers. If your A/V receiver only has one subwoofer jack, you can connect two RCA cables to a Y adapter and one cable to each subwoofer. The third way is to connect the first subwoofer normally and connect an RCA cable from the first subwoofer's line outputs to the second subwoofer's line inputs (see diagram above). In a home theater installation you will bypass both subwoofers' internal crossovers. For stereo installations you'll use and adjust both subwoofers' internal crossovers.

For connecting two subs wirelessly, you can pair both subs to a single transmitter. Note: connecting the first Speedwoofer wirelessly or using speaker level inputs will not pass the signal to the second Speedwoofer.



## Some Installation Tips

(Tips are always appreciated)

Most modern A/V receivers and processors include some type of auto setup and room correction. During the setup process, they will ask you to adjust the volume control on the subwoofer to a certain volume. In most situations, you do not have to follow this instruction exactly. Your goal should be to have the subwoofer's volume control as close to the vertical or 12 O'clock position as possible. This will give you the most flexibility to adjust the subwoofer's output up or down depending on what you're listening to. Most A/V receivers also allow you to adjust the subwoofer's volume by their remote.

The goal of a properly setup subwoofer is to produce accurate, controlled bass without sacrificing the teeth chattering impact some enjoy. The most common mistake people make is setting the subwoofer to play too loudly. The subwoofer should always blend seamlessly with your other speakers rather than being intrusive.

Your RSL Speedwoofer 10SMKII is powered by a conservatively-rated 400 watt RMS amplifier. Combined with its Compression Guide tuning, your Speedwoofer should be more than capable of providing an abundance of clean, powerful bass. In addition, the RSL Speedwoofer 10SMKII contains circuitry that helps prevent distortion when played at excessively loud volumes. However, **all subwoofers can be played loudly enough to be overdriven regardless of size, power, or price resulting in audible clipping (a form of distortion)**. In the unlikely event that you desire more bass, try placing the RSL Speedwoofer in a corner.

The RSL Speedwoofer 10SMKII has high quality, built-in protection circuitry, although no protection circuitry is foolproof. It's best to prevent the subwoofer from being over-driven in the first place. Here are a couple of indications of trouble to watch out for. If you notice the following taking place, reduce your subwoofer's volume until these symptoms disappear.

- Noise that doesn't sound natural. In movie scenes or music with heavy bass, listen for any noise that doesn't sound like it should be there. In some cases this can sound like a rattling or a very muddy rumble.
- Clipping. A good indication of clipping is if your subwoofer sounds excessively sloppy; as if it is flopping back and forth. This will produce some pretty ugly sounds. The RSL Speedwoofer 10SMKII uses high quality protection designed to keep clipping to a minimum.

If you're not sure if your subwoofer is being overdriven, remove the grill and look at the woofer itself. See if it appears as if it's moving back-and-forth excessively. The woofer should always move with tight, controlled precision. If you suspect the woofer's movement is excessive, try reducing your subwoofer's volume until it appears to move appropriately.

# A Discussion About Maximum Bass Output

When it comes to movies, the latest digital recording formats allow movie producers to incorporate an enormous amount of bass into their soundtracks. As a matter of fact, some movies produce bass that is more intense than larger-sized home theater subwoofers can handle. That is why virtually all modern subwoofers contain circuits that protect the subwoofer and its amplifier by limiting the maximum power that can be produced.

The amount of bass your system can produce is determined by several factors. For some, the bass produced by a single quality subwoofer like our Speedwoofer 10SMKII is more than plenty. Many of our customers report that they can't turn up their subwoofer nearly all the way without upsetting other members of their family. However for some, any amount of bass is never enough. It isn't our position to dictate how much bass is appropriate.

Another important factor is positioning. Depending on the position of the subwoofer, there will be peaks (where bass is more intense) and nulls (where bass is diminished). If you position the subwoofer so your listening position is in a null, you will not get adequate bass regardless of the size of your subwoofer or its volume setting. So, if you have the flexibility, spend some time determining the best position for your subwoofer.

If you have a very large listening room or simply desire more bass capability, we recommend considering a second subwoofer. This can add 6db of increased bass output, which is huge. This will allow both subwoofers to operate more efficiently with increased headroom for those explosive bass moments in movies.

## Care And Maintenance

- Clean your subwoofer using a soft, moist cloth (Windex or water is recommended), preferably microfiber or lint-free cloth. Do not put your subwoofer in the washing machine.
- Be very gentle when cleaning the front of your subwoofer, trying not to put pressure on the woofer itself.
- Be careful with liquids or beverages near your Speedwoofer. It does not play better when wet. Don't place flowers or plants that require watering on top of the subwoofer. Watering your Speedwoofer will not make it grow.
- Please keep your Speedwoofer away from direct sunlight and heat sources.
- If you operate the subwoofer with the grille off, please make sure that the woofer does not come in contact with anything as it can be damaged.
- Wires can loosen over time. Periodically make sure all connections to the Speedwoofer are tight. If a wire loosens and touches other wires, your system could be damaged.
- Do not expose your subwoofer to extremely hot or cold temperatures.
- Your Speedwoofer may not be used as a flotation device.

# Operating your RSL Speedwoofer 10S<sub>MKII</sub>

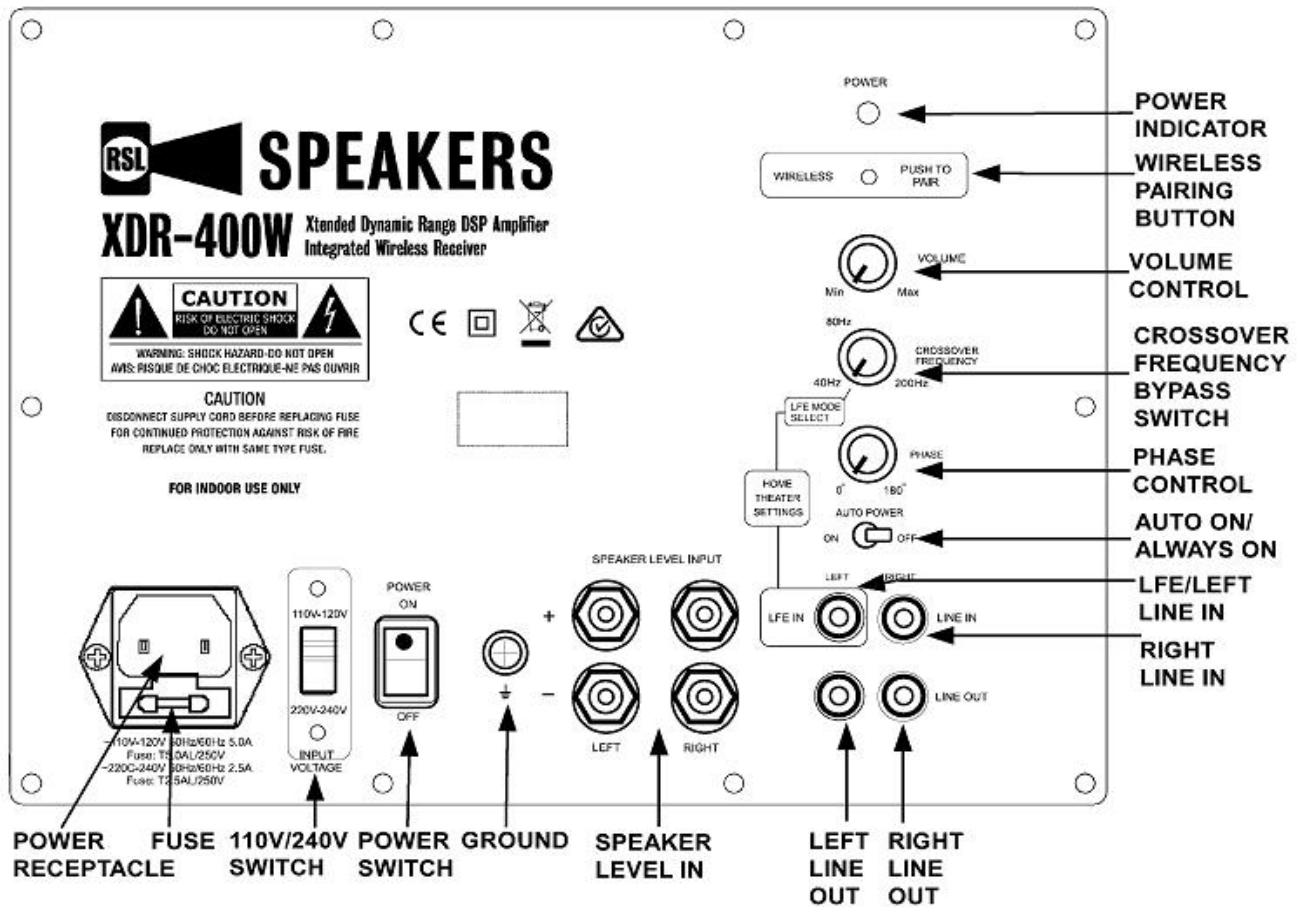

**Power Indicator** - When the indicator light is red, the Speedwoofer is in standby mode (when the auto power switch is set to on). When the Speedwoofer receives a signal, it will turn on and the light will change to green. If the light won't change to green, check the audio connection to the subwoofer (either the RCA connection or the wireless pairing light on the optional wireless transmitter). Please make sure your receiver's output volume to the subwoofer is adjusted high enough to trigger the auto on function. If the light isn't on at all, then the subwoofer isn't receiving power. Re-check the power switch, and AC power connection. Finally, check the fuse (see page 17).

**Wireless Pairing Switch** - To use your Speedwoofer wirelessly, you'll need to turn on the Speedwoofer and the transmitter. If the transmitter shows a solid light, it is paired and ready. If the light on the transmitter is flashing, it requires pairing. Please refer to the pairing procedure on page 14. Keep in mind that wireless operation can be affected by distance, objects or interference from your home's Wi-Fi network.

**Volume** - Controls the volume of bass output. During initial setup with your A/V receiver, we recommend that you set the volume control somewhere around the 12 o'clock position. That will allow maximum flexibility if you need to perform fine adjustments with the volume control at a later time. If you find that you have to turn the volume control up too high or down too low, refer to the setup in your A/V receiver to adjust the output volume to the subwoofer.



**Crossover-DSP Settings** – The crossover knob selects both the crossover frequency and also lets you select from two DSP sound modes. If the knob is turned fully counterclockwise until it clicks (LFE enabled), the internal crossover of the Speedwoofer is bypassed and the crossover function will be handled by your home theater receiver or processor. Also, with the Speedwoofer's crossover bypassed, the DSP mode will extend the Speedwoofer's bass response, which can be ideal for movies.

If the knob is rotated clockwise off the bypass position, the Speedwoofer's crossover is active, and you can select the appropriate frequency. For example, an 80Hz setting means your Speedwoofer will handle all frequencies at 80Hz and below. An 80Hz setting is recommended for larger bookshelf speakers. For smaller bookshelf speakers, we recommend a setting of 90-100Hz. We also suggest trying different crossover settings so that the Speedwoofer integrates seamlessly with the rest of your system.

When the internal crossover is active, the DSP will enable your Speedwoofer to deliver the same performance as our original Speedwoofer 10S. This may be a good choice if you primarily listen to music or if you wish to limit the bass that is transmitted to other rooms. To use this mode with your home theater receiver's internal crossover also active, turn the crossover knob fully clockwise. This will prevent the Speedwoofer's crossover from interfering with your home theater receiver's crossover.

**Phase** - Allows you to align the bass through subwoofer so it blends perfectly with the rest of the speakers. In addition, the phase should be adjusted so that the output in your room is maximum at the crossover frequency. If you're a bit techy, this can be determined using a sound level meter or a sound meter smartphone application and a pure tone that corresponds to the crossover frequency. The standard setting is 0 degrees, but some experimentation may be needed.

**Line In/LFE In** - LFE stands for low frequency effects. This is where the Speedwoofer receives the bass signal from your receiver or amplifier. For home theater, use a single RCA cable from the receiver's subwoofer or LFE output to the Speedwoofer's LFE in. For a two channel stereo system, use a stereo pair of RCA cables to the Speedwoofer's Line inputs.

**Line Out** - For a two channel system, this feeds the signal back to the amplifier for your other speakers. The Line Outs can also be used to connect an additional Speedwoofer. See the Dual Speedwoofer section.

**Speaker Level In** - This connection can be used in stereo systems with amplifiers that do not have pre-amplifier outputs. Please refer to the instructions at the top of page 13. Do not use this connection if you've already connected the Speedwoofer using any of the other methods.

**Ground** - In the unlikely event there is hum or noise when using the speaker level in connections, the ground connection can be used to ground the Speedwoofer to your other components. Please see the section on ground loop hum or noise on the next page.

**Input Voltage - Fuse** - Is Normally set for use in the U.S. and Canada at 115 Volts. **If your country's voltage is 230-240 Volts, you must change this setting before using the Speedwoofer. You must also change the fuse to a 2.5 amp fuse. The fuse location is just below the AC receptacle on the back of the subwoofer. Unfortunately, failure to do this will void your warranty.**

**Main Power Switch - Auto Power Switch** - The power switch will normally be left on. When switched on, and the auto/on switch is set to on, your Speedwoofer will go into standby mode (red light) until it receives an audio signal and then it will turn green. With no signal, it will return to standby mode after approximately 20 minutes. When the auto power switch is set to off, the Speedwoofer will always stay in operation mode (but consumes very little power, even at this setting). When connecting and disconnecting cables to the Speedwoofer, make sure the main power switch is off.

# Troubleshooting (For any issue you may call or email us. We'll be happy to help)

## **No Sound from Your subwoofer. Power indicator not lit.**

1. Check to confirm that your subwoofer's power switch is set to the "on" position and that the power cord has not been damaged and is securely plugged into the wall outlet. Verify that the wall outlet is powered.
2. Check the RSL Speedwoofer 10SMKII's removable fuse. It is located below the AC socket on the amplifier.

## **Accessing the fuse. Make sure the Speedwoofer is unplugged from the AC.**

To access the fuse, insert a flat-head screwdriver in the horizontal slot located on the power cord socket, just below where the cord plugs in. Gently pry the fuse housing open until it detaches. Extract the housing from the power cord socket, remove the fuse and inspect it. If the wire inside the cylinder is severed, displays a gap or looks burned, the fuse is bad and needs to be replaced. Replace with the a fuse of exactly the same value. The value is indicated below the power socket. If the new fuse blows, your subwoofer requires service. Please contact us.

The Speedwoofer has internal circuit protection that could be tripped. If you suspect this, turn down the subwoofer's volume and turn off the power. Wait 5 minutes before turning it on.

## **Ground loop hum or noise.**

Although a seldom occurrence, this can happen when speaker level inputs are used. It's not the fault of the subwoofer, but is caused by differences in the ground characteristics between different audio equipment. Fortunately, this is easy to fix. There are two methods. Connect a piece of wire from your audio amplifier's ground to the subwoofer amplifier's chassis. If your audio amplifier does not have a ground lug, then loosen a screw around the perimeter of the chassis. Wrap the stripped end of the wire around the screw and re-tighten. Then, connect the other end to the amplifier's ground screw. The hum should vanish.

As an alternative, if your amplifier has an unused RCA input, you can connect a single RCA cable to either the left or right jack and the other end to the subwoofer's RCA line out jack. This effectively connects the grounds of the two units together eliminating the hum.

## **Subwoofer will not go into standby mode.**

Make sure the auto power switch is set to on. If you are using the wireless transmitter, the Speedwoofer will always stay in operation mode. This is normal. In this mode, the Speedwoofer's power consumption is only slightly higher than in standby and the longevity of your Speedwoofer will not be affected. For more information please see wireless information on page 13.

If you are using a wired connection and the Speedwoofer stays in operation mode, it is because there is noise in either your AC or audio lines. Sometimes this noise will not be audible, but will be enough to keep the Speedwoofer in operation mode. Again, the power consumption is only slightly higher and the longevity will not be affected.

## **Specifications**

Frequency Response: 22-200 Hz+/- 3db, Overall Frequency Response: 18-200 Hz

Amplifier Power: 400 Watts RMS (1,000 or more Watts Peak Dynamic Power) Note: Peak power specs are not regulated and this is not how we prefer to rate power.

10" Aluminum Frame High-Excursion Woofer with Massive Double Magnet Structure  
Compression Guide Tuning Technology

Wireless Operation with Optional Wireless Transmitter Range: approximately 50 feet.

Dimensions: 16"H x 15"W x 17 3/4" D (Including AC Cord) Weight: 46 lbs.

# Peace Of Mind Warranty

We've worked countless hours without food, sleep, or television to build a subwoofer that will serve you well for many years. However, in the unlikely event it breaks and it's our fault, we'll fix it for free. Speakers are warranted for 5 years; electronics are warranted for 2 years.

We have designed the Speedwoofer to have its parts easily replaced by the user, requiring only a Phillips screwdriver and minimal technical knowledge. We may offer this solution to you in order to save you the expense and hassle of sending your subwoofer to us.

## **Here are the terms (sorry, our lawyer made us do this):**

RSL warranties your speakers for a period of 5 years from the date of purchase. We warranty our subwoofer amplifiers for a period of 2 years from the date of purchase. Our products are warranted to be free of defects in original materials and workmanship. Our warranties apply to the original purchaser. To obtain warranty service, we ask you to help us out with the following:

1. Be able to furnish a copy of your sales invoice. However, if you can't find it, we'll do our best to fire up the computer and look it up for you.
2. The serial numbers must be intact and match those on your sales invoice. Return authorization must first be obtaining by contacting us before sending your subwoofer to us. It must be properly packed.

Our speakers were designed for residential stereo or home theater use and must be used in this manner. They were not specifically designed for public address, musical instrument amplification, or other commercial or high intensity applications such as county fairs or NASCAR races. Such use is not covered under warranty.

Speakers returned under the terms of the warranty will be repaired or replaced at our option. We will pay for shipping the repaired product back to you if you live in the continental U.S., you are responsible for prepaying the shipping to us. Speakers that have been abused, operated improperly, improperly packed, tampered with, insulted or opened (without our prior permission) will not be repaired under warranty. This warranty does not cover damage caused by the use of faulty or improper audio/video components.

This is the total warranty. There are no other warranties, expressed or implied. No responsibility is assumed for any incidental or consequential damages. This warranty gives you specific legal rights, and you may have other rights which vary from state to state.

If you require service please contact us through our website or by phone (we promise to be nice about it even if you did something dumb).



A division of Rogersound Labs, LLC

26500 W. Agoura Road  
Suite 571  
Calabasas, CA 91302  
(800)905-5485

[www.rslspeakers.com](http://www.rslspeakers.com)